



67-11-5 Effective: November 26, 2007

## MACHINE SPECIFICATION

# BEL 505

## Semi-Automatic Case Former / Packing Station

The BEL 505 folds the bottom flaps of RSC case blanks opened and presented down into it by an operator and then firmly holds the case ready for packing. As the filled [or empty] case is pushed out of the 505 into an adjacent case sealer, the 505 resets itself automatically ready to receive the next case blank. The BEL 505 is entirely pneumatically operated and requires only compressed air at 80-90 psi. / 6 Bar.

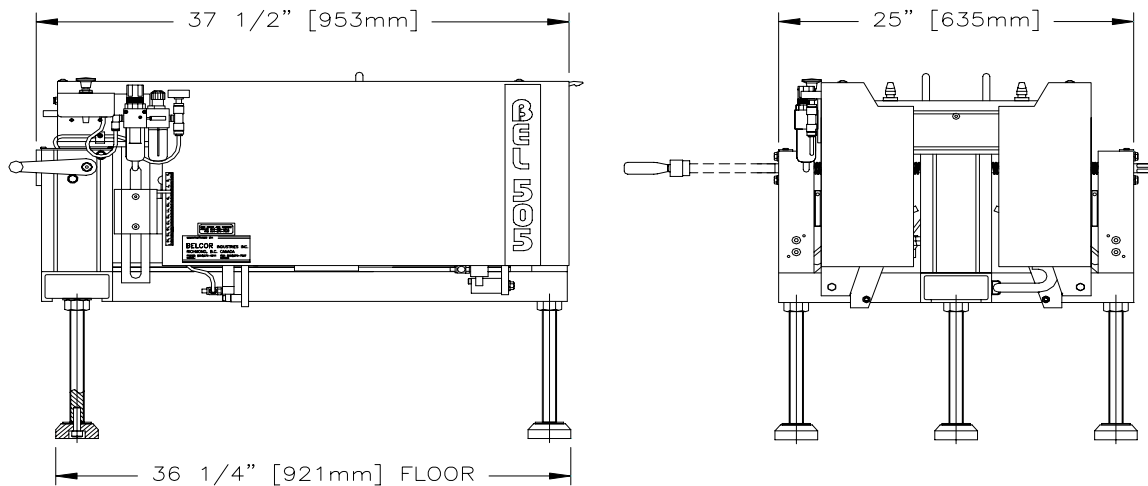

## STANDARD SPECIFICATIONS

		<u>Length</u>	<u>Width</u>	<u>Height</u>
<b>Case Size Range</b>	Minimum	8" / 203mm	6.0" / 152mm	3.5" / 89mm
	Maximum	26.5" / 673mm	16.0" / 406mm	unlimited
<b>Machine Dimensions</b>		37.5" / 700mm	25.0" / 635mm	18.5" / 470mm
<b>In/Outfeed Height</b>	Frame	22" / 560mm		
With adjustable leg extensions [foot pad]	Minimum	21.5" / 546mm		
	Maximum	28.5" / 724mm		
<b>Speed</b>		Up to 15 cases / min.		
<b>Shipping Weight</b>	Approx.	250 lbs. / 114 kg.		

For further detail, see Specification Sheet 67-11 and Layout Drawing 75-075

Wexxar Packaging Inc. a division of Pro Mach   
 Phone (604) 270-0811 • Fax (604) 270-7897  
 E-mail: sales@wexxar.com

**Construction:**

Anodized aluminum frame with attractive stainless steel covers and stainless steel fasteners. All operating components are fabricated from corrosion resistant materials for ease of cleaning and maintenance.

**Compressed Air Requirements:** 0.1 CF/Cycle @ 80-90 P.S.I. (6 Bar)

**Safety Provisions:**

Case blank must make contact with 3 separate control valves before machine will actuate. Operator's hands remain outside the machine perimeter and moving parts are behind guards.

**Nameplates / Identification:**

The machine Model Number and Serial Number appear on a nameplate and the serial number is stamped onto the machine frame.

**Documentation:**

- Operation & Service Manual - providing set up, operating and troubleshooting information
- Technical Reference – spare parts kits, assembly and parts reference drawings, pneumatic control diagrams

**WARRANTY**

On Machinery and Parts manufactured by the Company, Wexxar Packaging Inc. (the "Company") warrants to the original purchaser ("Buyer") of the product described above (the "Product") that:

- (a) all non-moving, structural components of the Product (excluding hot melt systems and tapeheads) in all material respects, will be free of defects due to imperfect material or workmanship for a period of One (1) year from the date of invoice;
- (b) all powered mechanical parts of the Product, in all material respects, will be free of defects due to imperfect material or workmanship for a period of at least one (1) year from the time of shipping from the Company's factory;

and following Company's acceptance of a warranty claim, upon the Buyer's delivery of the defective Product to the Company's factory, the Company will repair or replace it at the Company's option.

The warranties set out above do not extend or apply to:

- (a) the routine replacement of parts due to normal wear and tear arising from use; this warranty does not extend to parts which may presumably be expected to wear out during the warranty period;
- (b) damage attributable to accident, misuse, improper maintenance, power surge, improper connection to a power source, placement of Product in hostile environment, or alterations not authorized by the Company, negligence, or accident;
- (c) accessories, attachments, parts or instruments sold with or attached to the Product that do not bear the Company's trade mark ("Components");
- (d) any warranty claim not made in writing to the Company at its head office within the applicable warranty period and within ten (10) days of Product failure.
- (e) This warranty does not cover shipping costs;

This warranty shall be the only warranty in effect and is made exclusive of all other warranties and guaranties written or oral, expressed or implied.

**COMPONENTS**

On request and to the fullest possible extent, the Company will assign to the Buyer any interest it has in Component suppliers' warranties for separately manufactured parts and accessories which form; are attached to; or constitute part of the Product. This includes tape heads.

**CANCELLATION**

Orders cannot be cancelled without consent of an authorized employee of the Company and in such cases the customer will fully indemnify the Company, unless agreed otherwise in writing by the Company.

**TITLE**

The title and right of possession of the goods quoted hereto shall remain with the Company and such goods shall remain Company property until all payments have been made in full. The purchaser agrees to do all that is required to maintain such right and title with the Company.

**PRICE**

All prices quoted are F.O.B. Company warehouse unless otherwise specified. Prices quoted are subject to change and do not include taxes or duties, if applicable.



67-13-3 Effective: November 26, 2007

## MACHINE SPECIFICATION

# BEL 505XL

## Semi-Automatic Large Case Former / Packing Station

The BEL 505XL is a version of the BEL 505 series designed to handle case sizes up to 39" long and 24" wide [990mm x 610mm]. It folds the bottom flaps of large RSC case blanks opened and presented down into it by an operator and then firmly holds the case ready for packing. As the filled [or empty] case is pushed out of the 505XL into an adjacent case sealer, it resets itself automatically ready to receive the next case blank. The BEL 505XL is entirely pneumatically operated and requires only compressed air at 80-90 psi. / 6 Bar. Operator side or product flow direction needs to be specified at the time of a machine order in order to have all machine adjustments and controls accessible to the operator.

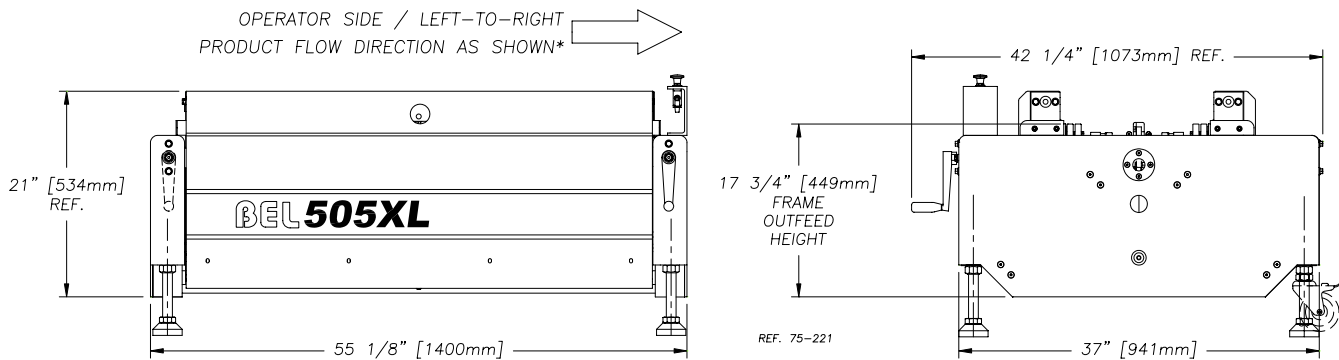

## STANDARD SPECIFICATIONS

		<u>Length</u>	<u>Width</u>	<u>Height</u>
<b>Case Size Range</b>	Minimum	10" / 254mm	10" [8.3**] / 254mm [210mm*]	3" / 76mm
	Maximum	39" / 990mm	24" / 610mm	-
<b>Machine Dimensions</b>		55.13" / 1400mm	37" / 940mm	21" / 534mm
<b>In/Outfeed Height</b>	Frame	17.75" / 450mm		
	With adjustable leg extensions [foot pad]	Minimum Maximum	18" / 457mm 26.5" / 673mm	
<b>Speed</b>		Up to 10 cases / min.		
<b>Shipping Weight</b>	Approx.	600lbs. / 273kg.		

\*Minimum case width of 8.3" [210mm] requires wrench changeover between smallest and larger sizes.  
For further detail, see Specification Sheet 67-13 and Layout Drawing 75-221

**Construction:**

**Packing Station** - Anodized aluminum frame with attractive stainless covers and stainless fasteners. All operating components are fabricated from corrosion resistant materials for ease of cleaning and maintenance.

**Tilt Base** – Zinc plated steel frame with black anodized aluminum end guard plates and powder coated aluminum side guard

**Compressed Air Requirements:** 0.25 CF/Cycle @ 80-90 P.S.I. (6 Bar)

**Safety Provisions:**

Case blank must make contact with 3 separate control valves before the packing station will actuate to fold the bottom flaps. Operator's hands remain outside the machine perimeter and moving parts are behind guards.

**Nameplates / Identification:**

The machine Model Number and Serial Number appear on a nameplate and the serial number is stamped onto the machine frame.

**Documentation:**

- Operation & Service Manual - providing set up, operating and troubleshooting information
- Technical Reference – spare parts kits, assembly and parts reference drawings, pneumatic control diagrams

**WARRANTY**

On Machinery and Parts manufactured by the Company, Wexxar Packaging Inc. (the "Company") warrants to the original purchaser ("Buyer") of the product described above (the "Product") that:

- (a) all non-moving, structural components of the Product (excluding hot melt systems and tapeheads) in all material respects, will be free of defects due to imperfect material or workmanship for a period of One (1) year from the date of invoice;
- (b) all powered mechanical parts of the Product, in all material respects, will be free of defects due to imperfect material or workmanship for a period of at least one (1) year from the time of shipping from the Company's factory;

and following Company's acceptance of a warranty claim, upon the Buyer's delivery of the defective Product to the Company's factory, the Company will repair or replace it at the Company's option.

The warranties set out above do not extend or apply to:

- (a) the routine replacement of parts due to normal wear and tear arising from use; this warranty does not extend to parts which may presumably be expected to wear out during the warranty period;
- (b) damage attributable to accident, misuse, improper maintenance, power surge, improper connection to a power source, placement of Product in hostile environment, or alterations not authorized by the Company, negligence, or accident;
- (c) accessories, attachments, parts or instruments sold with or attached to the Product that do not bear the Company's trade mark ("Components");
- (d) any warranty claim not made in writing to the Company at its head office within the applicable warranty period and within ten (10) days of Product failure.
- (e) This warranty does not cover shipping costs;

This warranty shall be the only warranty in effect and is made exclusive of all other warranties and guaranties written or oral, expressed or implied.

**COMPONENTS**

On request and to the fullest possible extent, the Company will assign to the Buyer any interest it has in Component suppliers' warranties for separately manufactured parts and accessories which form; are attached to; or constitute part of the Product. This includes tape heads.

**CANCELLATION**

Orders cannot be cancelled without consent of an authorized employee of the Company and in such cases the customer will fully indemnify the Company, unless agreed otherwise in writing by the Company.

**TITLE**

The title and right of possession of the goods quoted hereto shall remain with the Company and such goods shall remain Company property until all payments have been made in full. The purchaser agrees to do all that is required to maintain such right and title with the Company.

**PRICE**

All prices quoted are F.O.B. Company warehouse unless otherwise specified. Prices quoted are subject to change and do not include taxes or duties, if applicable.